

ZONEFIRST®

50 YEARS OF SERVICE

Installation Instructions

Model ZDSP and ZDBP

ZONE DAMPER

ZDBP – Bottom Mount



ZDSP – Side Mount



MINIMUM POSITION SETTING



The ZDSP & ZDBP have a minimum position setting that allows the damper to remain open to a pre-set position instead of closing off fully. This minimum position provides for a small amount of air to be by-passed through the damper to lessen the need for a separate by-pass damper and provide continual air circulation.

To set the minimum position, set when there is no power to the damper and it is in the open position. Open the minimum position cover, loosen the set screw and move to a desired setting shown on the minimum position label and re-tighten. When the damper is powered closed the minimum position screw will stop the damper at the position set.

NOTE: This label and screw does not indicate the position of the damper. It is only used to set the minimum position.

CHECKOUT

To checkout the operation of the dampers the control panel needs to be operating. It is recommended that each damper be checked before installing into the duct.

To check the damper, plug the damper into a zone on the control panel. Each zone of the panel has an LED that will be **Green** when the damper is to be **open**. When the panel LED is off, the damper will close and the damper LED will turn **RED**.

REPLACEMENT MOTOR

To replace the motor, loosen the locking set screw on the inside collar ring of the motor that holds the motor to the damper blade shaft, remove and replace with the new motor. And re-tighten the set screw.

6 Aspen Drive - Randolph, New Jersey 07869-1103
 Telephone 1-201-794-8004 FAX 1-201-794-1359
www.zonefirst.com info@zonefirst.com

© 2017 ZONEFIRST® Form 2043-0710

To Install, Cut a 4" Slot in the side of the duct the damper is to be inserted; Insert the damper and secure with sheet metal screws provided.

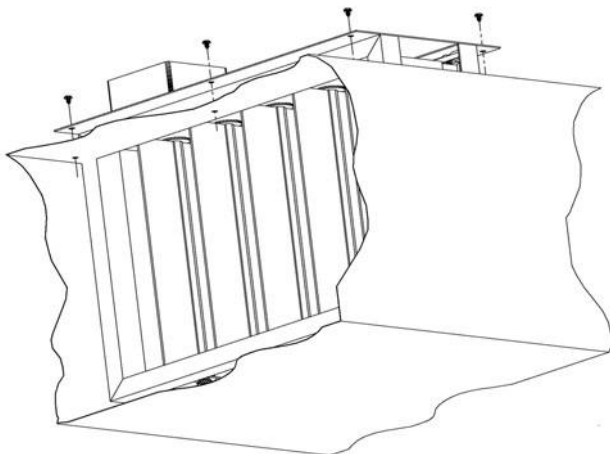

Bottom Mount Installation

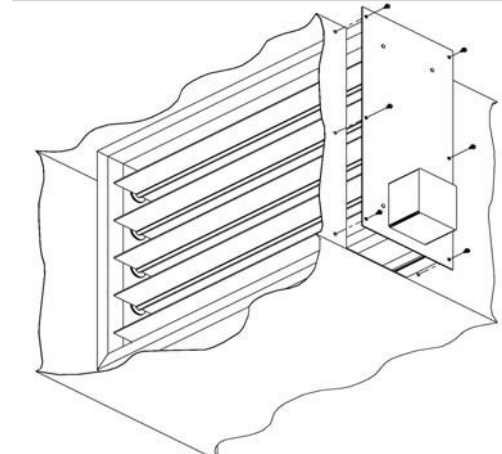

Side Mount Installation

INSTALLATION

WHEN INSTALLING THIS PRODUCT...

Read these instructions carefully. Failure to follow the instructions could damage the product or cause a hazardous condition. Ensure that the installer is a trained, experienced service technician. After completing installation, use these instructions to check product operation.

LOCATION

The Zone Dampers are installed typically near the furnace/air handler plenum and in the air duct takeoff to the zone. Always make sure the dampers are accessible for wiring, checkout, duct cleaning and replacement of damper or motor if ever needed.

DAMPER SIZE

To ensure proper operation, the ZD must be properly sized for the air duct. To ensure proper fit, damper sizes are built slightly smaller. 1/4" less than the listed dimensions. If the damper is forced into an undersized air duct, the excess pressure jams the damper blades and causes improper operation.

HUMIDIFICATION

Do not install dampers in heating systems where spray or atomizing type humidifiers are installed in the furnace plenum or air supply duct. Excessive lime or mineral deposits accumulate on damper blades and cause improper operation.

For humidification, use evaporative type humidifiers or return air type humidifiers.

INSTALLATION CONSIDERATIONS

Install Zone Dampers (ZDSP) or (ZDBP) into a squared air duct. Frame misalignment may jam the damper blades. Do not weld dampers to air ducts.

INSTALLING A ZONE DAMPER

Ensure the damper is correctly sized to the air duct and select a location near the furnace plenum.

1. Cut a 4-inch (102-millimeter) opening in one side (shorter dimension) of the air duct at the location selected. Ensure the opening is cut fully to the top and bottom air duct seams.
2. Slide the ZD into the cut opening of the air duct. Ensure the electric actuator is mounted toward the top of the air duct.
3. Secure the ZD mounting plate to the air duct with the sheet metal zip screws provided.

CAUTION

Locate and install dampers in an easily accessible location for Service and Checkout.

Never force dampers into undersized air ducts. Excess pressure will jam damper blades.

Ensure high limit setting is 200qF (93qC) or lower. Higher settings can damage electric actuator.

WIRING

ALL WIRING MUST CONFORM TO NEC STANDARDS AND ALL APPLICABLE LOCAL CODES.

The ZD damper is the simplest damper in the industry to wire. The ZD requires only an RJ11 cord for its 12 Volt DC, power-closed, power-open operation.

These Plug-In Dampers can ONLY be used with Plug-In Control Boards.

One 24VAC, 40VA Transformer can power up to ten (10) damper motors per zone.

To slave more than one motor together snap a cord into the first damper, using the second port on that motor, snap a cord from that damper to the next. No more than ten (10) dampers should be on one zone.

WIRING DIAGRAM 1

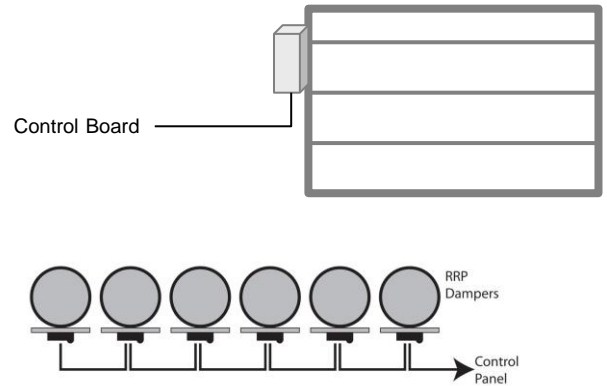

Test Damper

